



Mobile industrial dehumidifiers
DEH-500i / DEH-900i / DEH-1200i

» OPERATING AND MAINTENANCE
MANUAL



CONTENT

Introduction	2
Purpose	2
Content	2
Copyright	2
1. SAFETY AND APPLICATION	3
1.1 Safety of use	3
1.2 Application	4
2 DEVICE INFO.....	4
2.1 Standards	4
2.2 Description and principle of operation.....	4
2.3 Design	5
3 INSTALLATION AND OPERATION AREA.....	6
4 COMMISSIONING AND OPERATION	6
4.1 Electrical connection	6
4.2 Control Panel	6
4.3 Operating procedure and setting parameters	7
5 MAINTENANCE	8
5.1 Introduction	8
5.2 Housing.....	9
5.3 Filter	9
5.4 Heat exchanger	9
5.5 Fan motor	9
5.6 Compressor refrigeration system.....	9
6 DIAGNOSTICS AND TROUBLESHOOTING	9
7 DATA SHEET.....	11
8 PERFORMANCE DIAGRAMS.....	11
9 DIMENSIONS.....	12
10 CIRCUIT DIAGRAM.....	13



SAVE THIS MANUAL FOR FUTURE USES

Mobile industrial dehumidifiers DEH-500i / DEH-900i / DEH-1200i



DEH-900i/1200i

FOREWORD

Purpose

This user manual has been compiled to provide information about the equipment you have purchased and how to use it safely.

Content

The manual contains general information about safety and applications, operating principle, control of the drying process, maintenance standards, diagnostics and troubleshooting.

Copyright

We reserve all rights to update and clarify the information contained in this manual.

WARNING!!!



Some components inside the air dehumidifier housing carry high voltage. Please read this manual before use to avoid errors that could result in personal injury, equipment damage, or electric shock!
The equipment warranty is void if the unit has been improperly operated, maintained or modified.

1 SAFETY AND APPLICATION

1.1 Safety of use

All models of dehumidifiers in this series are manufactured in compliance with the requirements of European safety standards and current regulations. During design and production, the requirements for ensuring the safety of the operator and equipment were taken into account. This manual provides safety information and describes circumstances that may lead to abnormal situations. Such information is marked with a warning sign “ATTENTION!”.

This manual also provides basic information on how to maintain your dehumidifier. It is for informational purposes only and does not relieve the user of his responsibility to comply with personal safety requirements and local safety standards.

During the operation of the equipment, each user is obliged to comply with the instructions presented below:

- observe safety precautions when working with electrical equipment;
- follow the descriptions and instructions in this manual to ensure the protection of the user and equipment;
- before use, check the equipment for visible damage and operability;
- do not allow the use of the dehumidifier in explosive environments and rooms, as well as in places where the air contains various types of dust or aggressive substances: oils, salts, sulfur, chlorine, etc.;
- monitor the cleanliness of the heat exchangers and promptly service the dehumidifier;
- do not use the unit without a filter;
- do not block the air intake and air supply grilles;
- do not wash the unit under running water;
- observe the vertical position of the dehumidifier during transportation and operation;
- empty the condensate container on time (when used);
- do not use the equipment if there is a suspected malfunction;
- do not allow warning signs on the device to be removed;
- keep this manual near the dehumidifier.

1.2 Application

DEH-i series dehumidifiers use the condensation dehumidification method and are capable of effectively drying the air and automatically maintaining a given level of humidity at atmospheric pressure in the relative humidity range of 40 - 100% and operating temperature range from +10°C to +35°C.

Condensation dehumidifiers of this series are widely used in the following areas:

- elimination of the consequences of water flooding of various heated premises;
- heated warehouses for packaging and finished products;
- performing indoor construction and finishing work;
- production and storage of confectionery and food products;
- storage and aging of cheeses;
- drying fish, vegetables, fruits and starch;
- painting booths;
- testing laboratories;
- production facilities with high-precision equipment;
- premises with open tanks and swimming pools;
- laundries and premises requiring frequent wet cleaning;
- pumping stations;
- injection molding production areas;
- etc.

2 DEVICE INFO

2.1 Standards

The design of the dehumidifiers corresponds to the protection class IP22, IEC standard.

2.2 Description and principle of operation

The unit is designed for automatic and uninterrupted dehumidification and maintaining air humidity at atmospheric pressure.

The operation of the dehumidifier is based on the principle of condensation of moisture from the air. During operation of the dehumidifier, moist air is sucked into the dehumidifier by a fan and, passing through two heat exchangers of the compressor refrigeration machine, is first cooled in the “cold” heat exchanger (evaporator) below the dew point temperature with condensation, and then heated in the “warm” heat exchanger (condenser) and is discharged from the dehumidifier into the room being dried. The moisture released from the air in the form of condensate flows into the internal tray, and then by gravity, at the user’s choice, is discharged either into a built-in removable tank or directly into the sewer system.

The dehumidifier is controlled and monitored through a control panel equipped with an LCD display. The display can show current and adjustable parameters, operating modes, as well as service information in cases of a malfunction.

During operation, continuous repeated air circulation occurs through the dehumidifier and its humidity in the room gradually decreases.

Please note that the air temperature leaving the dehumidifier in dehumidifying mode is always approximately 5 °C higher than the air temperature entering the dehumidifier.

It should also be borne in mind that the performance of the dehumidifier directly depends on the humidity and temperature of the air being dried. The lower the air temperature and humidity, the lower the dehumidifier's performance will be.

The dehumidifier is equipped with a function for monitoring the presence of a removable tank and its filling level. If there is no tank or it is completely full, the display will show "Tank Full" and the dehumidifier itself will automatically turn off until the cause is eliminated.

To use a removable tank to collect condensate, you need to insert the hose from the condensate tray into the tank. To drain condensate directly into the sewer, it is necessary to connect the hose from the condensate collection tray from the inside to the fitting on the side wall of the dehumidifier, and use the supplied corrugated hose from the outside from the fitting to the sewer. In this case, the dehumidifier can operate continuously, without stopping to drain condensate from a filled tank.

If the heat exchanger freezes while the dehumidifier is operating, the automatic system turns off the compressor to defrost, and the fan continues to operate. After defrosting the heat exchanger, the compressor turns on automatically and air drying continues. Operating modes are displayed on the control panel.

The dehumidifier is equipped with a removable, washable G1 filter to clean the incoming air. The use of a dehumidifier without a filter is prohibited due to contamination of the heat exchanger, subsequent corrosion of its elements and, as a result, deregistration of the system.

Dehumidifier operation schematic diagram

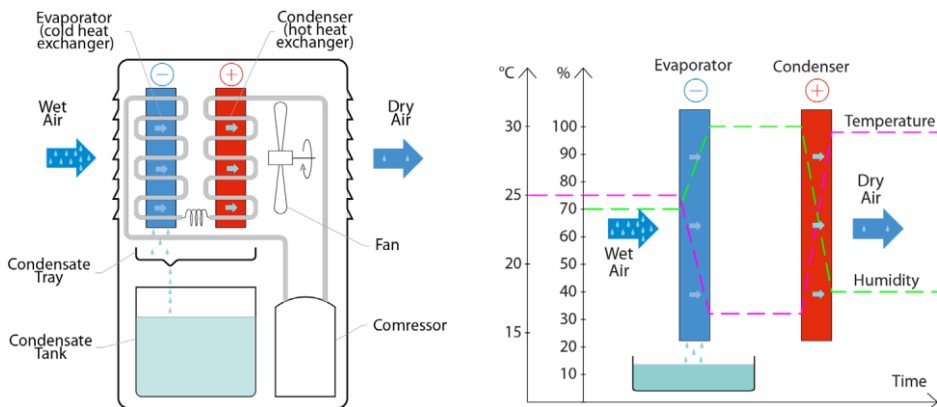

2.3 Dehumidifier design

The dehumidifier has a powder-coated metal body that is resistant to corrosion.

Behind the removable panel of the front lower part of the case there is a tank for collecting condensate. On the front upper part of the case there is an incoming air filter, which is fixed with a removable grille.

The dehumidifier is equipped with tubeless wheels and a transport handle for easy movement.

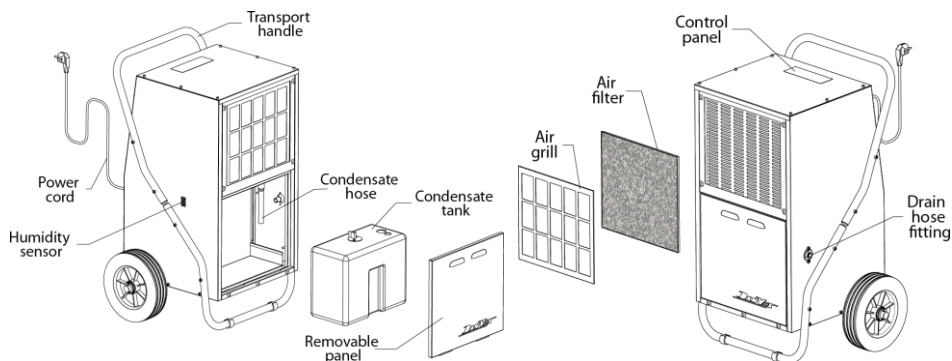

3 INSTALLATION AND OPERATION AREA

To ensure proper, economical and safe operation of the dehumidifier, the following recommendations must be observed:

- move the equipment carefully and avoid physical damage to the installation when moving to the place of operation;
- do not place the dehumidifier in close proximity to radiators or other heat sources;
- install the dehumidifier on a level base in a vertical position to properly drain condensate into the built-in tank or into the sewer system;
- if possible, place the dehumidifier in the center of the room to be dried or in the middle of a long wall to ensure optimal air circulation;
- do not cover or block the ventilation grilles of the unit to ensure unimpeded circulation of dry air through the dehumidifier;
- Close windows and doors, and also limit the performance of the ventilation system to avoid excessive flow of moist air into the room being dried.

4 COMMISSIONING AND OPERATION

4.1 Electrical connection



All electrical equipment works must be carried out in accordance with the safety standards of the country in which the equipment is used!

- It is prohibited to connect the dehumidifier to a power supply whose power and frequency are outside the nominal values of the dehumidifier;
- When using extension cables, they must be fully extended, grounded and of sufficient wire cross-section.

4.2 Control Panel

The control panel is used to set dehumidification parameters and control the operation of the installation. The panel contains waterproof control buttons and an LCD display. The buttons are used to turn the dehumidifier on/off, set the desired humidity level, and also control the timer. The display shows operating modes, the level of required humidity and current air parameters at the location where the dehumidifier is installed.

Control buttons:

- ON/OFF** - turning on/off the dehumidifier;
- TIMER/SETUP** - selecting a mode for setting humidity, timer and defrosting parameters;
- +** - increasing of setting value;
- - decreasing of setting value.

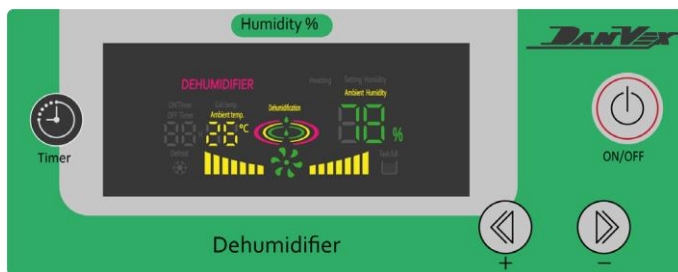

4.3 Operating procedure and setting parameters

The dehumidifier is turned on by pressing the ON/OFF button once, a short beep sounds and the LCD display lights up.

To enter **the humidity setting mode**, press the "Timer/Setup" button once. The **"SET"** icon and the set humidity value will start flashing. At this time, press "+" or "-" to adjust the set value. The beep will sound once each time the key is pressed and the humidity value on the display will increase or decrease by "1". Press and hold the "+" or "-" key for 2 seconds to continuously increase or decrease the set humidity (setting range: 10%-95%, default: 50%). After entering the required humidity, wait 5 seconds and the humidity value on the display will stop flashing.

When the set humidity value is below 10%, the dehumidifier will enter continuous drying mode and the display will show "CO".

If the current humidity level is higher than the set level by at least 2-3%, the dehumidifier will start working. Once the dehumidifier is turned on, it operates in fully automatic mode. The dehumidifier will turn off when the specified humidity level is reached.

To enter **the timed start setting mode**, after turning on the dehumidifier, press the "Timer/Setup" button twice. The **"T OFF"** icon and the red digits for the timer value on the display will begin to flash. At this time, press the "+" or "-" button to adjust the set value. Each key press will be accompanied by a beep sound and the set time will increase or decrease by "1" hour. After holding continuously for 2 seconds, the timer time can be continuously increased or decreased (setting range: 0-24 hours, default 0 hours)

Press the "Timer/Setup" button again to enter **the timed shutdown setting mode**. The **"T ON"** icon and the red digits of the timer value on the display will begin to flash. At this time, press "+" or "-" to adjust the set value. Each key press will be accompanied by a beep sound and the set time will increase or decrease by "1" H. After holding continuously for 2 seconds, the set time can be continuously increased or decreased (setting range: 0-24 hours, default 0 hours).

To set **the defrost mode**, press the “Timer/Setup” button several times until the “**FROST**” icon appears. The defrost indicator will flash and the digital time display tube will flash. At this time, press “+” or “-” to set the defrost timeout value. Each key press will be accompanied by a beep sound and the set time will increase or decrease by “5” minutes (setting range 0, 20, 25-60 minutes, default 0 minutes).

To display **the heat exchanger temperature sensor value**, press the “Timer/Setup” and “+” buttons simultaneously for 5 seconds. Press these buttons again or press other buttons to return to the normal display.

By subsequently pressing the “Timer/Setup” button, the controller will enter **the RS485 communication address setting mode** and the numbers will begin to flash on the display. At this time, press “+” or “-” to adjust the set value. Each key press will be accompanied by a beep sound and the set value will increase or decrease by “1” (setting range from 1 to 99, default is 1).

Please note that the RS485 connector is only present on the control board inside the dehumidifier and is not present on the dehumidifier housing!

To lock the control panel buttons, press the “Timer/Setup” and “-” buttons simultaneously for 5 seconds, the “**DEHUMIDIFIER**” icon will flash. To unlock, use the same buttons.

Automatic startup sequence for dehumidifier components after switching on:

1. fan start
2. starting the compressor after a short delay

The unit is equipped with a protection that prevents the compressor from starting when restarted immediately after being switched off, thus preventing damage to the compressor. The compressor start delay is 3 minutes.

Attention:

- The dehumidifier will not start if the humidity level specified in the settings is higher than the current humidity;
- The dehumidifier will not start if the tank is full or missing;
- When operating in low temperature conditions, the dehumidifier compressor may automatically switch off to perform defrosting and the defrost indicator  will light up on the display;
- The display shows the humidity range from 30% to 90%;
- If the dehumidifier is not to be used for a long period of time, unplug it from the power supply.

5 MAINTENANCE



Before starting any maintenance work, be sure to disconnect the power supply to the dehumidifier!

5.1 Introduction

It is important to regularly inspect, maintain and clean the main components of the dehumidifier to ensure long service life and trouble-free operation. The frequency of maintenance depends on the operating conditions of the dehumidifier. In this way, the maintenance cycle can be determined based on actual operation. Incomplete and incorrect maintenance may reduce the effectiveness of the dehumidifier or cause it to break down.

5.2 Housing

Dust and other substances must not accumulate on the dehumidifier housing. It is recommended to clean the housing with a dry or slightly damp cloth, without using solvents or abrasive detergents. Use only non-aggressive cleaning agents, even if the installation is heavily soiled.

Do not clean the unit under running water!

5.3 Filter

The dehumidifier is equipped with a washable coarse air filter at the inlet. It protects the dehumidifier heat exchangers from lint and household dust. Do not run the dehumidifier without a filter. It is recommended to clean the filter as it becomes clogged, but at least once every 2 weeks.

5.4 Heat exchanger

If the dehumidifier is used correctly with the air filter installed, the heat exchanger does not require maintenance. However, when operating in environments where there is a high level of dust in the air, which is not normal operating conditions, the heat exchanger may need to be cleaned. In such cases, it is necessary to carefully clean the heat exchanger under running warm water without using solvents or aggressive detergents, first disassembling the dehumidifier housing, protecting the electrical components and then blowing the heat exchanger with compressed air.

5.5 Fan motor

The fan motor is equipped with rolling bearings, the service life of which corresponds to the service life of the motor.

5.6 Compressor refrigeration system

The compressor system is a closed cycle system and does not require special maintenance. If necessary, all diagnostic and maintenance actions must be performed by a specialized specialist or an authorized service center.

6 DIAGNOSTICS AND TROUBLESHOOTING

For high-quality and long-term operation, the unit was subjected to control and testing during the manufacturing process. However, if problems arise during operation, use the following recommendations:

Condition	Possible reason	Actions to resolve
The dehumidifier does not turn on (the display is not illuminated)	<ul style="list-style-type: none"> • no power supply • fuse failure 	<ul style="list-style-type: none"> • check the connection and voltage • check the fuse
The dehumidifier does not start (the display is illuminated)	<ul style="list-style-type: none"> • humidity level is set to high • tank is full or missing • restart after emergency shutdown • heat exchanger freezing • humidity sensor is faulty • fan motor is faulty 	<ul style="list-style-type: none"> • reduce humidity in settings • empty and install the tank • compressor start delay 3 minutes • check the message on the display and wait for defrosting • check the display for errors • check fan rotation

Condition	Possible reason	Actions to resolve
No condensation or little condensation (fan running)	<ul style="list-style-type: none"> • low air humidity or low temperature • the filter or heat exchanger is clogged • refrigerant leak • compressor malfunction 	<ul style="list-style-type: none"> • check air parameters for proper operation • clean the filter or heat exchanger • check the display for errors • check the start of the compressor by sound and the presence of an error on the display

If a malfunction occurs in the dehumidifier control system or the refrigeration circuit, the display shows an error code instead of the temperature reading.

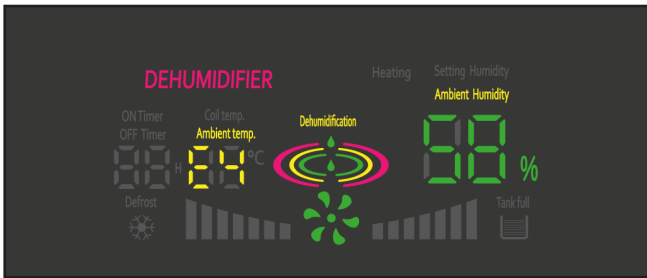

Errors list:

- E1 - heat exchanger temperature sensor is faulty
- E3 - the temperature and humidity sensor is faulty
- E4 (flashing) - refrigeration system malfunction: refrigerant leak or compressor malfunction
- E5 - high refrigerant temperature in the system
- E7 - the working current of the compressor is too high



Operating a dehumidifier with a clogged filter or heat exchanger will lead to overheating of the compressor and failure, which is not a warranty case!

7. DATA SHEET

Model	DEH-500i	DEH-900i	DEH-1200i
Capacity (at 30 °C/80%RH), L/day	59	90	120
Operating temperature range, °C	+10...+35		
Humidity range, RH%	30...100		
Process air flow, m3/h	500	840	1400
Condensate tank capacity, liter	10	14	14
Direct drainage	Yes	Yes	Yes
Drain water pump	No		
Current, A	3,8	5,3	6,8
Power consumption, kW	880	1150	1380
Voltage / frequency	230V / 50Hz		
Refrigerant	R290*180g	R290*250g	R290*300g
Noise level, dB(A)	< 64	< 64	< 64
IP protection	IP22		
Air filter class	G1		
Dimensions (depth*width*height), mm	see drawing		
Weight, kg	39	52	54

8. PERFORMANCE CHARTS

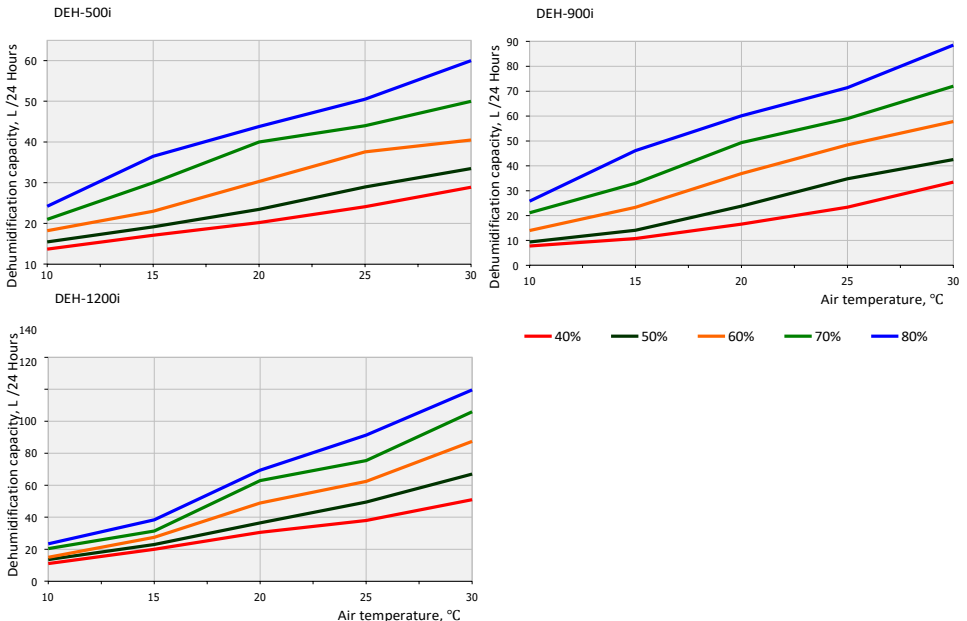

9. DIMENSIONS

DEH-500i

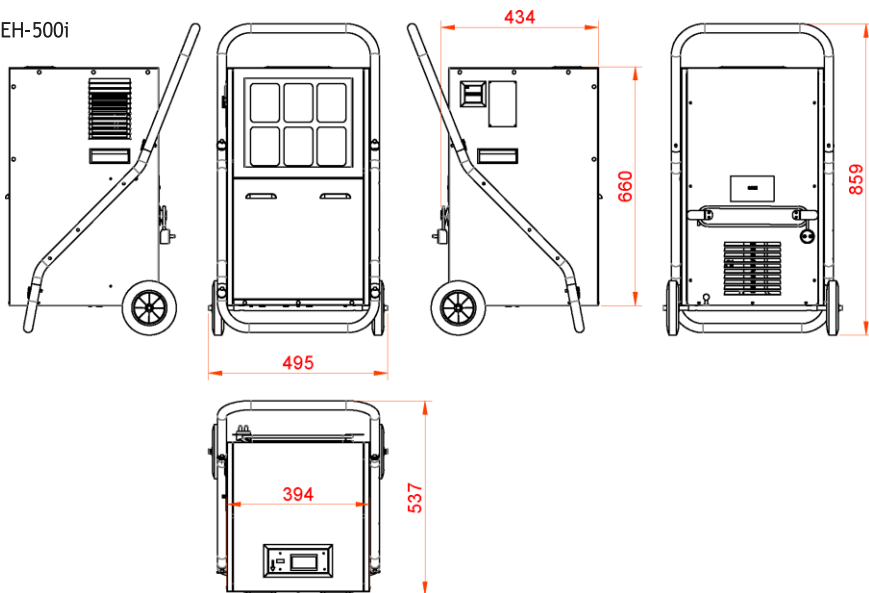

DEH-900i/1200i

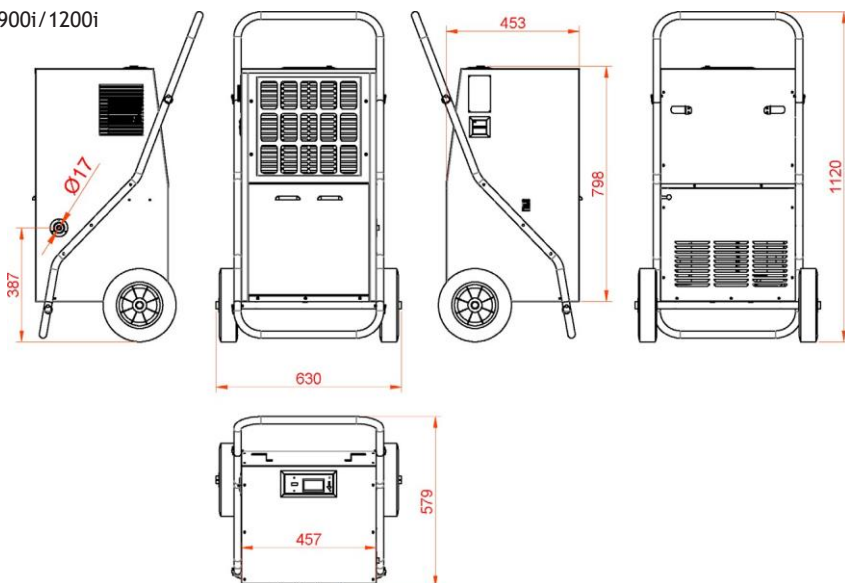

10. CIRCUIT DIAGRAM

DEH-500i
DEH-900i
DEH-1200i

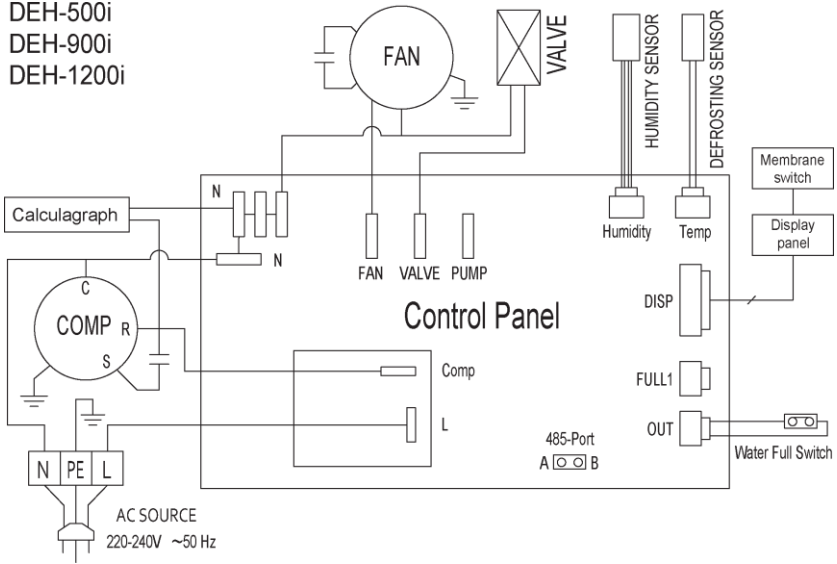



DANVEX[®]

WWW.DANVEX.COM

