



Mobile dehumidifier DEH-1000p

»» Operation manual



rev. 1.10

Table of Contents

SAFETY INFORMATION 3

TRANSPORTATION, MARKING AND STORAGE 4

OPERATING INSTRUCTION 5

CONTROL PANEL DESCRIPTION 5

DRAINING INSTRUCTION 7

MAINTENANCE INSTRUCTION 8

TROUBLESHOOTING 8

ERRORS 12

SPECIFICATIONS..... 13

SAFETY INFORMATION

1. Do not use means to accelerate the defrosting process or to clean, other than those recommended by the manufacturer.
2. The appliance shall be stored in a room without continuously operating ignition sources (for example: open flames, an operating gas appliance or an operating electric heater.)
3. Do not pierce or burn.
4. Be aware that refrigerants may not contain an odour.
5. Appliance shall be installed, operated and stored in a room with a floor area larger than 10 m²
6. Servicing shall be performed only as recommended by the manufacturer.
7. The appliance shall be stored in a well- ventilated area where the room size corresponds to the room area as specified for operation.
8. All working procedure that affects safety means shall only be carried by competent persons.
9. Please read the manual carefully before the first time using this product, and storage the unit in safe place to avoid electricity leakage, flaming or person injure.
10. Do not put this product in the water or any other liquids.
11. If the supply cord is damaged, it must be replaced by the manufacturer, its service agent or similarly qualified persons in order to avoid a hazard.
12. Please ask professional service agent to repair the product. Improper repair might cause damage to users.
13. Disconnect the appliance from power supply before moving or cleaning the product, and also when the product is not in used.
14. Please operate the product with specified electricity voltage.
15. Please use this product only for household appliance and follow the designed purpose.
16. Do not put any stuff on the product.
17. In order to avoid water leakage, please clean the water tank before moving the product.
18. Do not incline the product, or leaking water may damage the product.
19. This appliance can be used by children aged from 8 years and above and persons with reduced physical, sensory or mental capabilities or lack of experience and knowledge if they have been given supervision or instruction concerning use of the appliance in a safe way and understand the hazards involved. Children shall not play with the appliance. Cleaning and user maintenance shall not be made by children without supervision.
20. Please keep the product from the wall or other barriers in a minimum distance of 50 cm.
21. The appliance shall be installed in accordance with national wiring regulations.
22. The applicable operating temperature range for this unit is 10-35°C.
23. Do not operate your dehumidifier in a wet room such as a bathroom or laundry room.
24. Spaces where refrigerant pipes shall be compliance with national gas regulations.



TRANSPORTATION, MARKING AND STORAGE

1. Transport of equipment containing flammable refrigerants Compliance with the transport regulations
2. Marking of equipment using signs
 1. Compliance with local regulations
 2. Disposal of equipment using flammable refrigerants Compliance with national regulations
3. Storage of equipment/appliances
4. The storage of equipment should be in accordance with the manufacturer's instructions.
5. Storage of packed (unsold) equipment
6. Storage package protection should be constructed such that mechanical damage to the equipment inside the package will not cause a leak of the refrigerant charge. The maximum number of pieces of equipment permitted to be stored together will be determined by local regulations.
7. The appliance shall be stored so as to prevent mechanical damage from occurring.
8. General work area
9. All maintenance staff and others working in the local area shall be instructed on the nature of work being carried out. Work in confined spaces shall be avoided. The area around the workspace shall be sectioned off. Ensure that the conditions within the area have been made safe by control of flammable material.

OPERATING INSTRUCTION

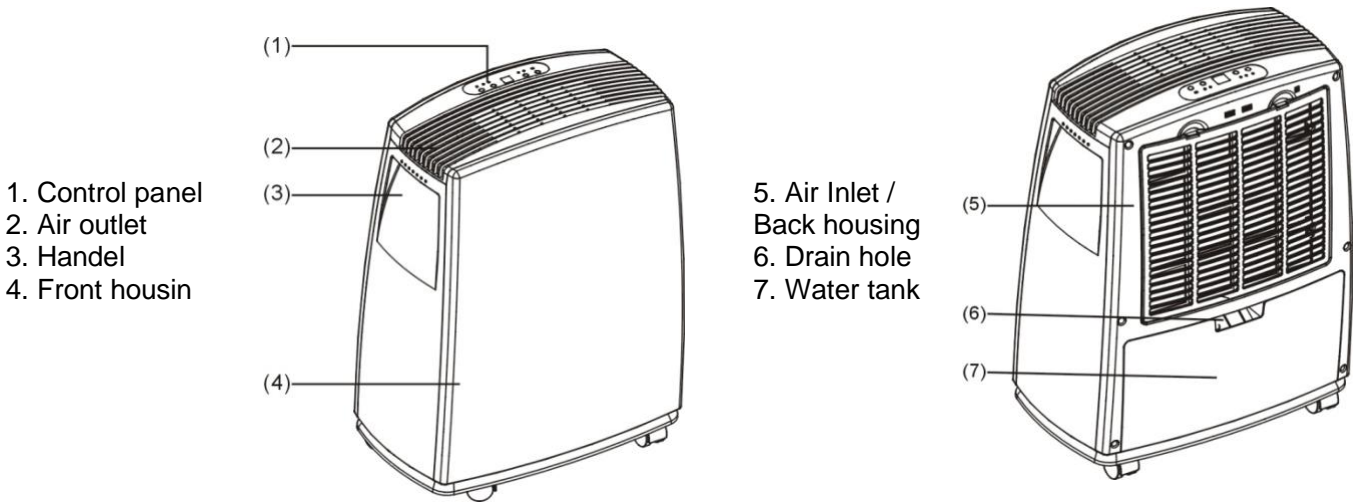

CONTROL PANEL DESCRIPTION

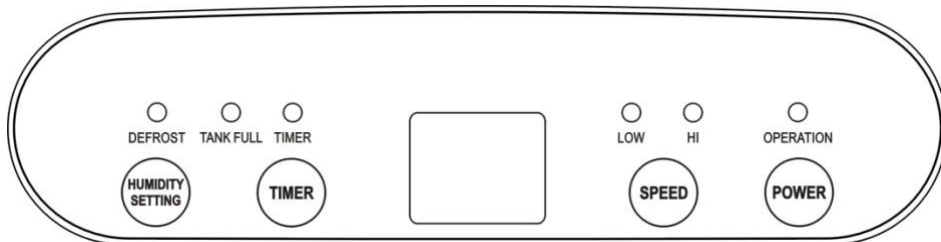

OPERATING

1. Power

Press the key to turn “on” or “off”.

2. Fan Speed

Press the key to choose high speed (HI) or low speed (LOW).

3. Timer

a. Press the key to set time you need (1 to 24 hours), and then the related indicating light will illuminate.

b. When setting timer in stand-by mode, the unit will be turned on automatically; when setting timer in operating mode, the unit will be turned off automatically.

c. If pressing the power key to turn on/off the unit before time finishes counting down, the setting timer will be canceled.

4. Humidity Setting

Press the key to set the relative humidity you need. (From RH30%, 35%, 40%, 45%, ...90%, comfort mode [AU], to continuous dehumidification [CO].

When ambient humidity is lower than setting humidity by 3%, compressor will stop automatically, and return working until the ambient humidity is higher than setting humidity

Comfort Mode [AU]

- a. When ambient temperature is lower than 5°C, compressor will stop working.
- b. When ambient temperature is higher than 5°C and lower than 20°C, the product will set the humidity to 60% automatically.
- c. When ambient temperature is higher than 20°C and lower than 27°C, the product will set the humidity to 55% automatically.
- d. When ambient temperature is higher than 27°C, the product will set the humidity to 50% automatically.

WATER FULL

When the water tank is full, the indicating light will illuminate and the unit will stop working until empty the water tank.

WARNING

1. When operating the dehumidifier, please do not set the humidity higher than ambient humidity.
2. When indicating light which shows the water tank is full illuminates, please pour the water out of the tank and put it back. Then the product will resume working.
3. When the product shut down, please wait at least 3 minutes before restarting the unit to prevent damaging the compressor.
4. The applicable operating temperature range for this unit is 5-35°C.
5. If the dehumidifier can't start (the indicating light does not illuminate) or the dehumidifier shut down unreasonably, please make sure whether the plug is connected firmly to power supply. If the plug and power supply are in normal condition, please wait for 10 minutes before restart the unit (because it takes 10 minutes to reposition). If the unit still does not start after 10 minutes, please ask your local distributor service station to repair.
6. When the dehumidifier is operating, it's a normal situation that the working compressor may cause some heat and bring the ambient temperature up.
7. When the product is defrosting, related indicating light will illuminate. And during the defrosting, the compressor will stop but the motor will keep working.
8. The unit shows the ambient humidity when it's operating. If the ambient humidity is higher than RH95%, the display shows "HI"; if the ambient humidity is lower than RH35%, the display shows "LO"

DRAINING INSTRUCTION

Draining water can storage in the water tank, or be continuous drained by PVC tube. (The PVC tube is not included in the product.)

USAGE OF WATER TANK

When dehumidifying, the condensing water may be drained to water tank. And the unit will stop working with indicating light illuminates when the water tank is full of water, please pour out the water that time.

1. Take out the water tank as Fig 01 and pour out the water.
2. Put the water tank back.
3. Press power key to turn on the unit.

Fig 01

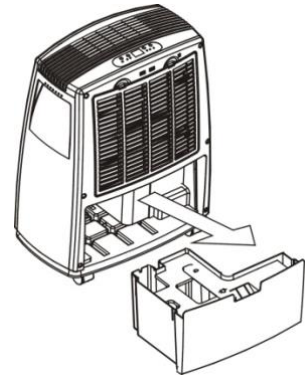

CONTINUOUS DRAINAGE

1. Before continuous draining water, please take out the water tank and plug a draining tube to draining hole (see Fig 02.) Then put the water tank back.
2. Draining tube should place lower than the draining hole to let water flow out.

Fig 02

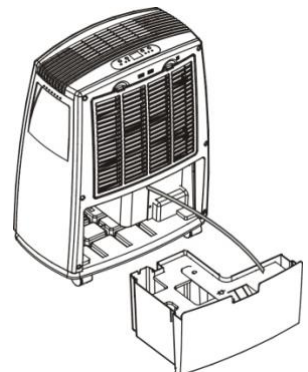

FILTER REMOVAL

1. To remove the filter please press the filter's buckles down, and then remove the filter directly.
2. Wash the filter with cool water (cooler than 40°C) every two weeks, and put filter back after it air-dried naturally.

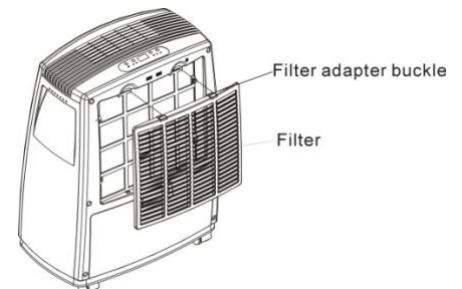

MAINTENANCE INSTRUCTION

1. The unit is not allowed to be placed on surface which is soft or not flat to avoid the unit cause noise, vibration, and water or electricity leakage when operating.
2. Never insert any slim rod or hard stuff into the unit to avoid the damage of the unit.
3. Please disconnect the power cord to the power supply when you turn off the unit or intend to stop using for long time.

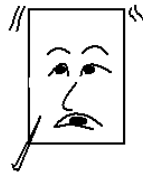
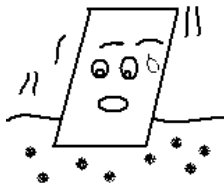

4. In order to improve the performance of dehumidifier, please keep the unit in open place from barriers to block the air.
5. Please wash the filter with cool water (cooler than 40°C) but not gasoline or alcohol every two weeks, and put filter back after it air-dried naturally.

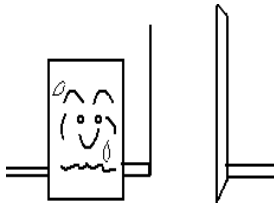

TROUBLESHOOTING

INFORMATION ON SERVICING

1. Checks to the area

Prior to beginning work on systems containing flammable refrigerants, safety checks are necessary to ensure that the risk of ignition is minimized. For repair to the refrigerating system, the following precautions shall be complied with prior to conducting work on the system.

2. Work procedure

Work shall be undertaken under a controlled procedure so as to minimize the risk of a flammable gas or vapour being present while the work is being performed.

3. Checking for presence of refrigerant

The area shall be checked with an appropriate refrigerant detector prior to and during work, to ensure the technician is aware of potentially flammable atmospheres. Ensure that the leak detection equipment being used is suitable for use with flammable refrigerants, i.e. non-

sparkling, adequately sealed or intrinsically safe.

4. Presence of fire extinguisher

If any hot work is to be conducted on the refrigeration equipment or any associated parts, appropriate fire extinguishing equipment shall be available to hand. Have a dry powder or CO₂ fire extinguisher adjacent to the charging area.

5. No ignition sources

No person carrying out work in relation to a refrigeration system which involves exposing any pipe work that contains or has contained flammable refrigerant shall use any sources of

ignition in such a manner that it may lead to the risk of fire or explosion. All possible ignition sources, including cigarette smoking, should be kept sufficiently far away from the site of installation, repairing, removing and disposal, during which flammable refrigerant can possibly be released to the surrounding space. Prior to work taking place, the area around the equipment is to be surveyed to make sure that there are no flammable hazards or ignition risks. "No Smoking" signs shall be displayed.

6. Ventilated area

Ensure that the area is in the open or that it is adequately ventilated before breaking into the system or conducting any hot work. A degree of ventilation shall continue during the period that the work is carried out. The ventilation should safely disperse any released refrigerant and preferably expel it externally into the atmosphere.

7. Checks to the refrigeration equipment

Where electrical components are being changed, they shall be fit for the purpose and to the correct specification. At all times the manufacturer's maintenance and service guidelines shall be followed. If in doubt consult the manufacturer's technical department for assistance.

The following checks shall be applied to installations using flammable refrigerants:

- The charge size is in accordance with the room size within which the refrigerant containing parts are installed;
- The ventilation machinery and outlets are operating adequately and are not obstructed;
- If an indirect refrigerating circuit is being used, the secondary circuit shall be checked for the presence of refrigerant;
- Marking to the equipment continues to be visible and legible. Markings and signs that are illegible shall be corrected;
- Refrigeration pipe or components are installed in a position where they are unlikely to be exposed to any substance which may corrode refrigerant containing components, unless the components are constructed of materials which are inherently resistant to being corroded or are suitably protected against being so corroded.

8. Checks to electrical devices

Repair and maintenance to electrical components shall include initial safety checks and component inspection procedures. If a fault exists that could compromise safety, then no electrical supply shall be connected to the circuit until it is satisfactorily dealt with. If the fault cannot be corrected immediately but it is necessary to continue operation, an adequate temporary solution shall be used. This shall be reported to the owner of the equipment so all parties are advised.

Initial safety checks shall include:

- That capacitors are discharged: this shall be done in a safe manner to avoid possibility of sparking;
- That there no live electrical components and wiring are exposed while charging, recovering or purging the system;
- That there is continuity of earth bonding.

REPAIRS TO SEALED COMPONENTS

1. During repairs to sealed components, all electrical supplies shall be disconnected from the equipment being worked upon prior to any removal of sealed covers, etc. If it absolutely necessary to have an electrical supply to equipment during servicing, then a permanently operating form of leak detection shall be located at the most critical point to warn of a potentially hazardous situation.

2. Particular attention shall be paid to the following to ensure that by working on electrical components, the casing is not altered in such a way that the level of protection is affected. This shall include damage to cables, excessive number of connections, terminals not made to original specification, damage to seals, incorrect fitting of glands, etc.

Ensure that apparatus is mounted securely.

Ensure that seals or sealing materials have not degraded such that they no longer serve the purpose of preventing the ingress of flammable atmospheres. Replacement parts shall be in accordance with the manufacturer's specifications.

NOTE: The use of silicon sealant may inhibit the effectiveness of some types of leak detection equipment. Intrinsically safe components do not have to be isolated prior to working on them.

REPAIR TO INTRINSICALLY SAFE COMPONENTS

Do not apply any permanent inductive or capacitance loads to the circuit without ensuring that this will not exceed the permissible voltage and current permitted for the equipment in use.

Intrinsically safe components are the only types that can be worked on while live in the presence of a flammable atmosphere. The test apparatus shall be at the correct rating. Replace components only with parts specified by the manufacturer. Other parts may result in the ignition of refrigerant in the atmosphere from a leak.

CABLING

Check that cabling will not be subject to wear, corrosion, excessive pressure, vibration, sharp edges or any other adverse environmental effects. The check shall also take into account the effects of aging or continual vibration from sources such as compressors or fans.

DETECTION OF FLAMMABLE REFRIGERANTS

Under no circumstances shall potential sources of ignition be used in the searching for or detection of refrigerant leaks. A halide torch (or any other detector using a naked flame) shall not be used.

LEAK DETECTION METHODS

The following leak detection methods are deemed acceptable for systems containing flammable refrigerants.

Electronic leak detectors shall be used to detect flammable refrigerants, but the sensitivity may not be adequate, or may need re-calibration. (Detection equipment shall be calibrated in a refrigerant-free area.) Ensure that the detector is not a potential source of ignition and is suitable for the refrigerant used. Leak detection equipment shall be set at a percentage of the LFL of the refrigerant and shall be calibrated to the refrigerant employed and the appropriate percentage of gas (25 % maximum) is confirmed.

Leak detection fluids are suitable for use with most refrigerants but the use of detergents containing chlorine shall be avoided as the chlorine may react with the refrigerant and corrode the copper pipe-work.

If a leak is suspected, all naked flames shall be removed/ extinguished.

If a leakage of refrigerant is found which requires brazing, all of the refrigerant shall be recovered from the system, or isolated (by means of shut off valves) in a part of the system remote from the leak. Oxygen free nitrogen (OFN) shall then be purged through the system both before and during the brazing process.

REMOVAL AND EVACUATION

When breaking into the refrigerant circuit to make repairs – or for any other purpose –conventional procedures shall be used. However, it is important that best practice is followed since flammability is a consideration. The following procedure shall be adhered to:

- Remove refrigerant;
- Purge the circuit with inert gas;
- Evacuate;
- Purge again with inert gas;
- Open the circuit by cutting or brazing.

The refrigerant charge shall be recovered into the correct recovery cylinders. The system shall be “flushed” with OFN to render the unit safe. This process may need to be repeated several times. Compressed air or oxygen shall not be used for this task. Flushing shall be achieved by breaking the vacuum in the system with OFN and continuing to fill until the working pressure is achieved, then venting to atmosphere, and finally pulling down to a vacuum. This process shall be repeated until no refrigerant is within the system. When the final OFN charge is used, the system shall be vented down to atmospheric pressure to enable work to take place. This operation is absolutely vital if brazing operations on the pipe-work are to take place. Ensure that the outlet for the vacuum pump is not close to any ignition sources and there is ventilation available.

CHARGING PROCEDURES

In addition to conventional charging procedures, the following requirements shall be followed.

- Ensure that contamination of different refrigerants does not occur when using charging equipment. Hoses or lines shall be as short as possible to minimize the amount of refrigerant contained in them.
- Cylinders shall be kept upright.
- Ensure that the refrigeration system is earthed prior to charging the system with refrigerant.
- Label the system when charging is complete (if not already).
- Extreme care shall be taken not to overfill the refrigeration system. Prior to recharging the system it shall be pressure tested with OFN. The system shall be leak tested on completion of charging but prior to commissioning. A follow up leak test shall be carried out prior to leaving the site.

DECOMMISSIONING

Before carrying out this procedure, it is essential that the technician is completely familiar with the equipment and all its detail. It is recommended good practice that all refrigerants are recovered safely. Prior to the task being carried out, an oil and refrigerant sample shall be taken in case analysis is required prior to re-use of reclaimed refrigerant. It is essential that electrical power is available before the task is commenced.

- a) Become familiar with the equipment and its operation.
- b) Isolate system electrically.
- c) Before attempting the procedure ensure that:
 - Mechanical handling equipment is available, if required, for handling refrigerant cylinders;
 - All personal protective equipment is available and being used correctly;
 - The recovery process is supervised at all times by a competent person;
 - Recovery equipment and cylinders conform to the appropriate standards.
- d) Pump down refrigerant system, if possible.
- e) If a vacuum is not possible, make a manifold so that refrigerant can be removed from various parts of the system.
- f) Make sure that cylinder is situated on the scales before recovery takes place.
- g) Start the recovery machine and operate in accordance with manufacturer's instructions.
- h) Do not overfill cylinders. (No more than 80 % volume liquid charge).
- i) Do not exceed the maximum working pressure of the cylinder, even temporarily.
- j) When the cylinders have been filled correctly and the process completed, make sure that the

cylinders and the equipment are removed from site promptly and all isolation valves on the equipment are closed off.

k) Recovered refrigerant shall not be charged into another refrigeration system unless it has been cleaned and checked.

LABELLING

Equipment shall be labelled stating that it has been de-commissioned and emptied of refrigerant. The label shall be dated and signed. Ensure that there are labels on the equipment stating the equipment contains flammable refrigerant.

RECOVERY

When removing refrigerant from a system, either for servicing or decommissioning, it is recommended good practice that all refrigerants are removed safely.

When transferring refrigerant into cylinders, ensure that only appropriate refrigerant recovery cylinders are employed. Ensure that the correct number of cylinders for holding the total system charge is available. All cylinders to be used are designated for the recovered refrigerant and labelled for that refrigerant (i.e. special cylinders for the recovery of refrigerant). Cylinders shall be complete with pressure relief valve and associated shut-off valves in good working order. Empty recovery cylinders are evacuated and, if possible, cooled before recovery occurs.

The recovery equipment shall be in good working order with a set of instructions concerning the equipment that is at hand and shall be suitable for the recovery of flammable refrigerants. In addition, a set of calibrated weighing scales shall be available and in good working order. Hoses shall be complete with leak-free disconnect couplings and in good condition. Before using the recovery machine, check that it is in satisfactory working order, has been properly maintained and that any associated electrical components are sealed to prevent ignition in the event of a refrigerant release. Consult manufacturer if in doubt.

The recovered refrigerant shall be returned to the refrigerant supplier in the correct recovery cylinder, and the relevant Waste Transfer Note arranged. Do not mix refrigerants in recovery units and especially not in cylinders.

If compressors or compressor oils are to be removed, ensure that they have been evacuated to an acceptable level to make certain that flammable refrigerant does not remain within the lubricant. The evacuation process shall be carried out prior to returning the compressor to the suppliers. Only electric heating to the compressor body shall be employed to accelerate this process. When oil is drained from a system, it shall be carried out safely.

ERRORS

Problems	Cause of problem	Solution
E1	Temperature sensor error, or the control system is off	Please contact service agent or similarly qualified persons for repairing
E2	Coil sensor error, or the control system is off	

SPECIFICATIONS

Model	DanVex DEH-1000p
Specification	
Moisture Removal (30°C, RH80%)	80 liters/day
Applicable temperature	5°C - 35°C
Refrigerant	R290, 0.20 kg
Permissible Excessive Operating Pressure	
Suction:	0.6MPa
Discharge	2.5MPa
Maximum Allowable Pressure	4.0MPa
Water Tank Capacity	7.2L
Voltage	220-240V ~50Hz
Current	3.2 A
Power	740W
Noise level	46 dB(A)
Dimension (W x D x H)	481 x 286 x 628, mm
Net weight	23.8 kg

- ⚠ This marking indicates that this product should not be disposed with other household wastes throughout the EU. To prevent possible hazards to the environment or human health from uncontrolled waste disposal, please recycle it to prove the sustainable reuse of material resources. Please ask return and collection systems.

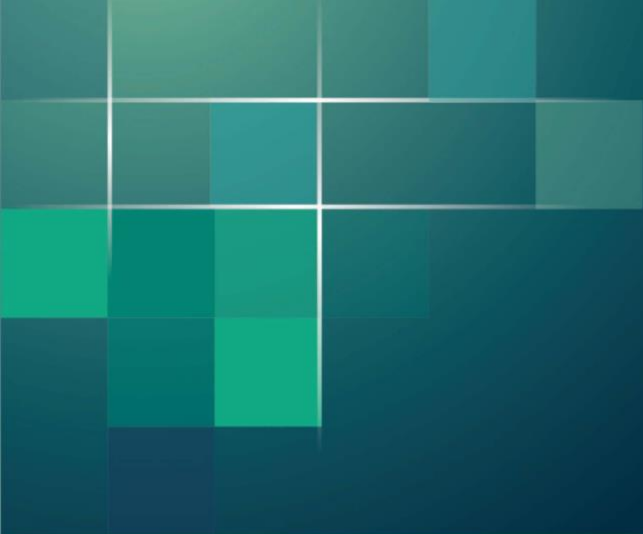

www.danvex.com

